



Parts Manual

Mfg. No: 030207-01
10,000 Watt Briggs & Stratton

Model Components	Page
Alternator (200891).....	4
Control Panel (200889).....	6
Main Unit (317669).....	8
Wheel Kit (200892).....	14
Wiring Diagram (199939WD).....	16
Wiring Schematic (199939WS).....	18
Torque Specification Chart.....	20

Not For
Reproduction

Alternator (200891)

Note: Unless noted otherwise, use the standard torque specifications

Mfg. No: 030207-01

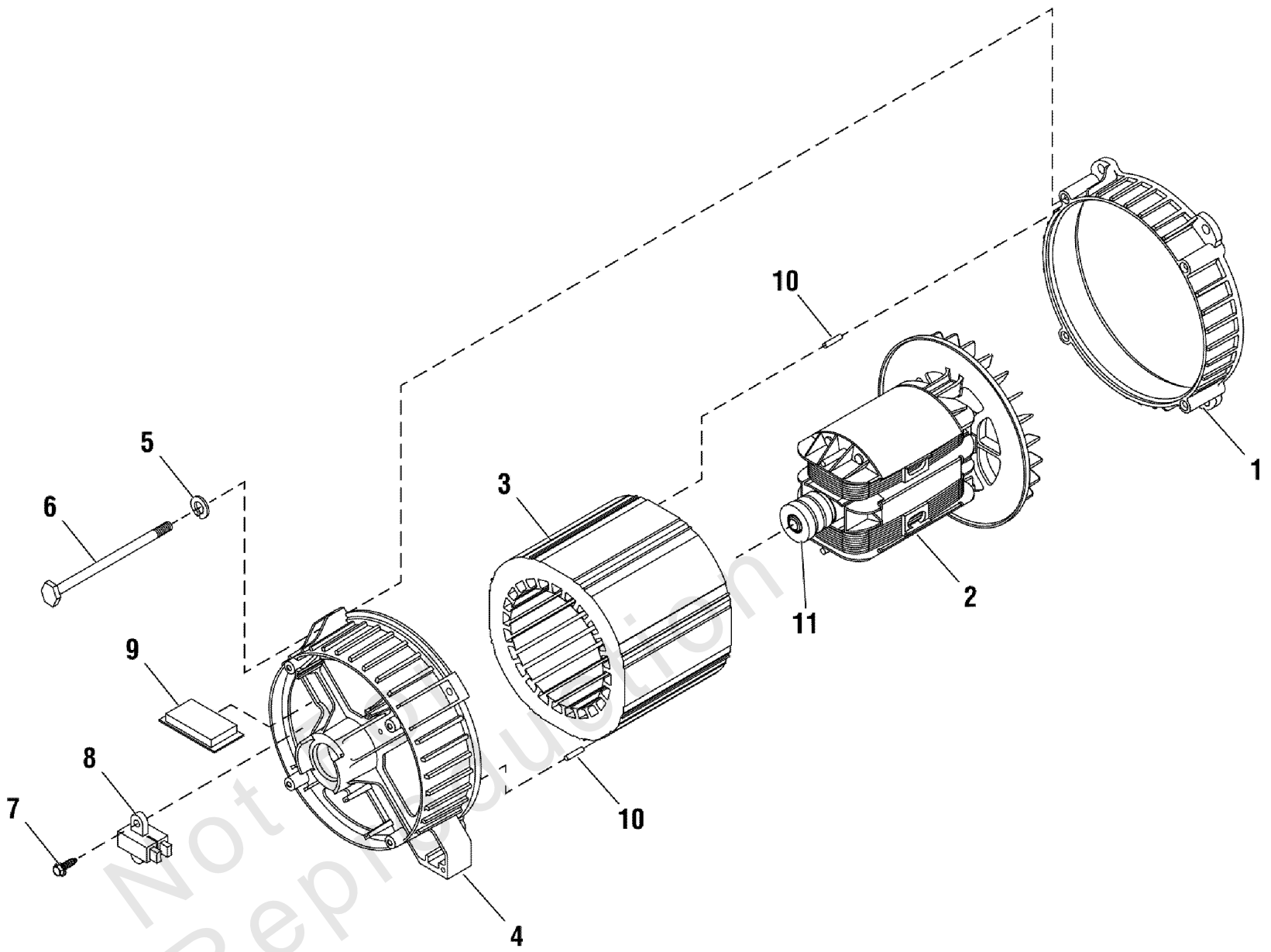

Alternator (200891)

REF NO	PART NO	QTY	DESCRIPTION
1	209599GS		ADAPTER, Alternator
2	191952GS		ROTOR
3	191953GS		STATOR
4	186060GS		CARRIER, Bearing
5	-		* WASHER, Lock, 1/4-M6
6	66449LGS		SCREW
7	66849GS		TAPTITE, M5 - 0.8 x 16
8	66386GS		BRUSH ASSEMBLY
9	205858GS		REGULATOR, Voltage
10	81917GS		PIN
11	65791GS		BEARING

Not For
Reproduction

Control Panel (200889)

Note: Unless noted otherwise, use the standard torque specifications

Mfg. No: 030207-01

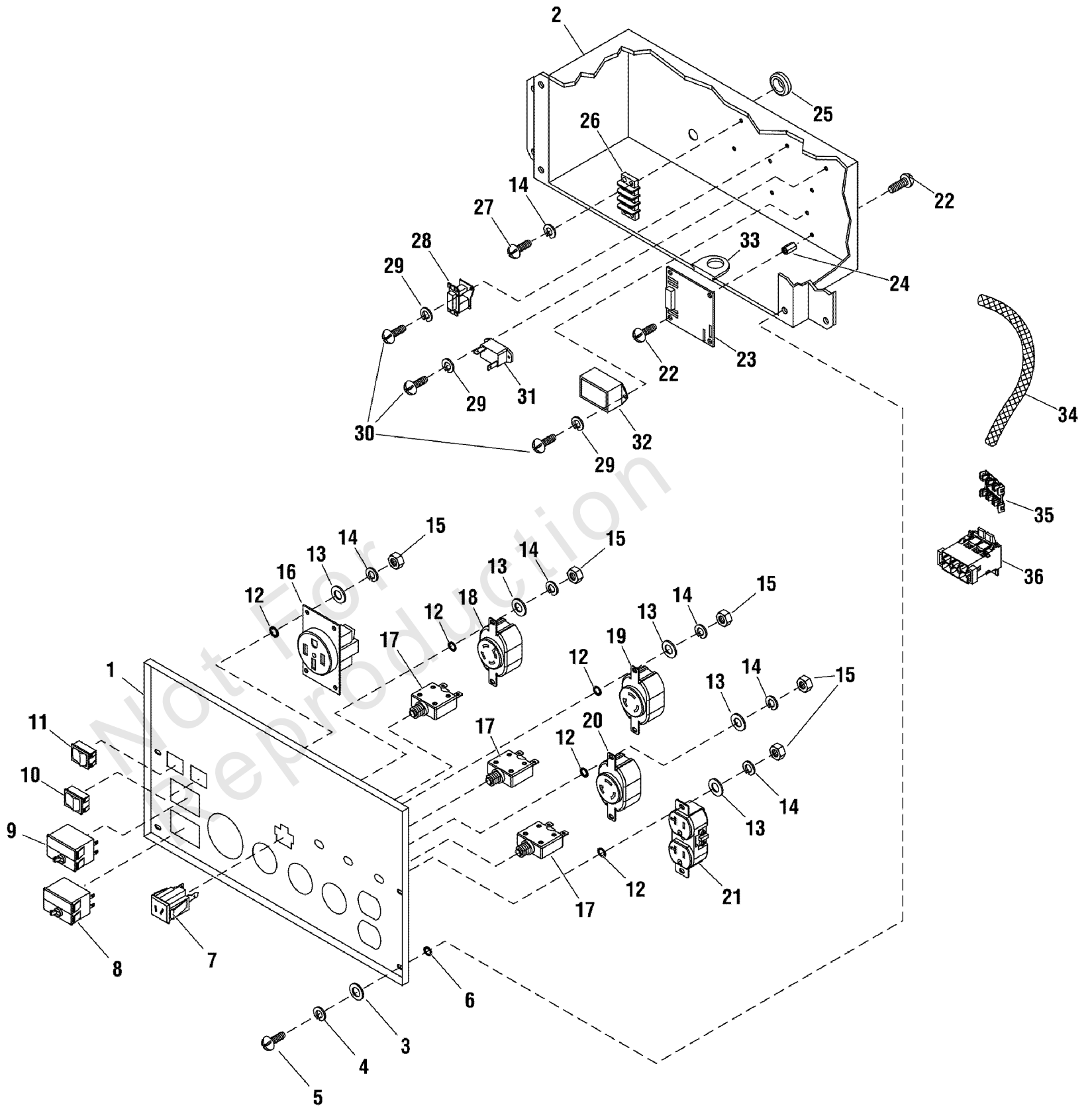

Control Panel (200889)

REF NO	PART NO	QTY	DESCRIPTION
1	199022BNGS		PANEL, Control
2	201864GS		BOX, Control Panel
3	-		* WASHER, Flat, #10 - M5
4	-		* LOCKWASHER, M5
5	-		* SCREW, Phillips Head, M5 - 0.8 x 12
6	-		* WASHER, Shakeproof, M6 - 1/4
7	90418GS		OUTLET, 12V DC Snap
8	191480BGS		BREAKER, Circuit, 40A, 2P
9	191480AGS		BREAKER, Circuit, 30A, 2P
10	82538GS		SWITCH, On/Off
11	78653GS		SWITCH, On/Off
12	-		* WASHER, Shakeproof, Int. #8
13	-		* WASHER, Flat, M4
14	-		* LOCKWASHER, M4
15	-		* NUT, M4 - 0.7
16	B4262GS		OUTLET, 125/250V 50A
17	75207GS		BREAKER, Circuit, 20A
18	43437GS		OUTLET, 120/240V, TL30A
19	68868GS		OUTLET, 120V, 30A
20	74190GS		OUTLET, 120V, 20A
21	68759GS		OUTLET, 120V, 20A, Duplex
22	-		* PHTS, 6 - 32 x 3/8"
23	195406GS		BOARD, Idle Control
24	64525GS		STANDOFF, Hex, 3/4"
25	62265GS		GROMMET
26	92953GS		TERMINAL, Block
27	-		* PPHMS, M4 - 0.7 x 20
28	84028GS		TRANSFORMER, Idle Control
29	-		* LOCKWASHER, M3
30	-		* PHMS, M3 - 0.5 x 10
31	87962GS		BREAKER, Circuit, 10A
32	77314GS		RELAY
33	188632GS		BOOT, Rubber Wire Outlet
34	194273GS		TUBING
35	199532GS		STRIP, Dual Row, TPA, 6 Circuit
36	199528GS		CONNECTOR

Footnotes:

* Items without part numbers are common fasteners and are available at your local hardware store.

Main Unit (317669)

Note: Unless noted otherwise, use the standard torque specifications

Mfg. No: 030207-01

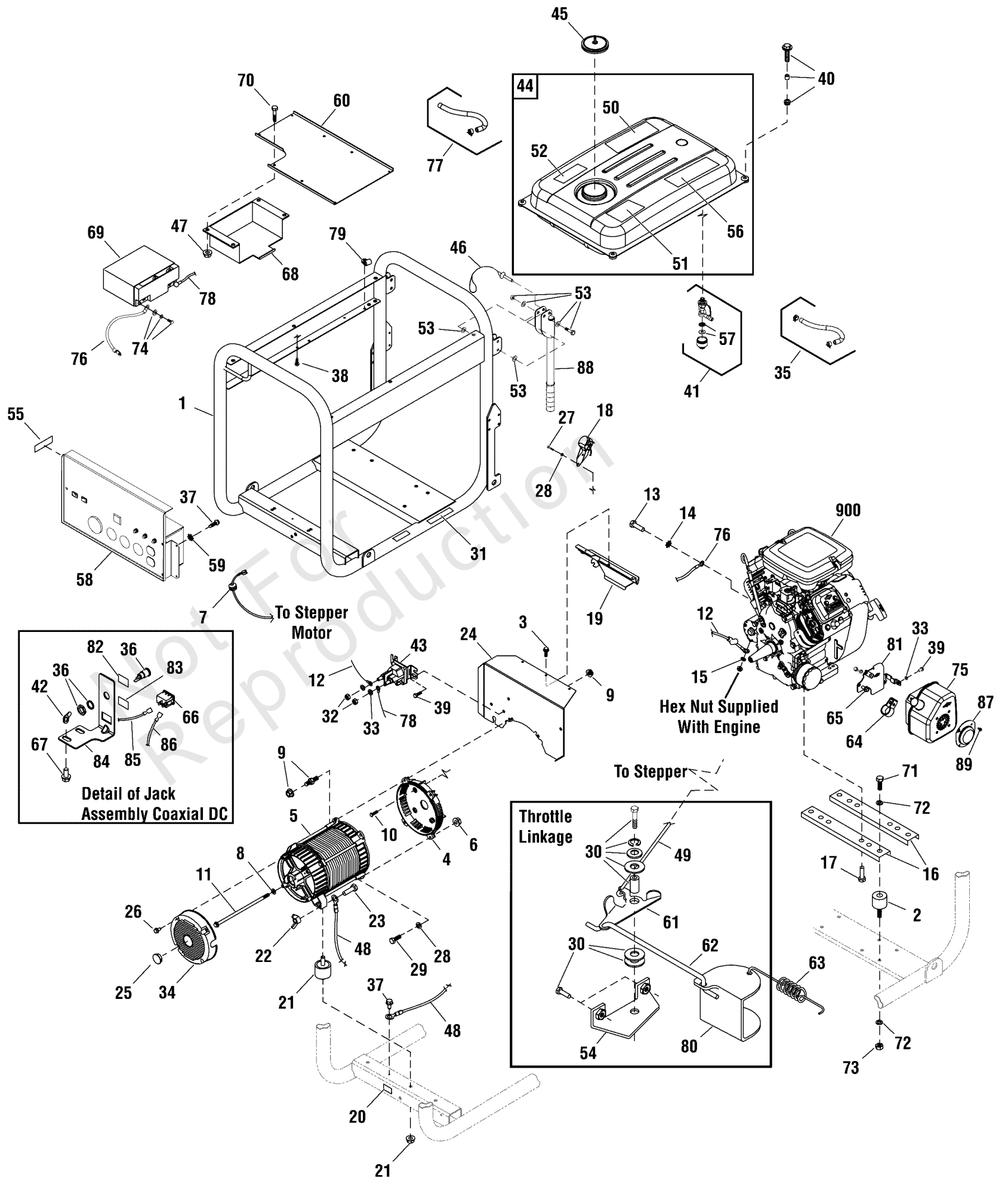

Main Unit (317669)

REF NO	PART NO	QTY	DESCRIPTION
1	200968BNGS		KIT, Cradle -(Includes Ref. Nos. 20 & 31)
2	38353GS		MOUNT, Vibration
3	56893GS		CRIMPTITE, 10-24 x 1/2
4	190220GS		ADAPTER, Engine
5	-		ALTERNATOR
6	-		* NUT, Hex, M8 - 1.25
7	62265GS		GROMMET
8	96796GS		WASHER, 8.4 x 22.2 x 3
9	194208GS		KIT, Hardware, Heatshield
10	190274BGS		BOLT, Shoulder, 3/8-16 x 1"
11	187365DGS		CAPSCREW, Hex Head, 5/16-24 x 10.28
12	189302SGS		WIRE
13	-		* CAPSCREW, Hex Head, M8 - 1.25 x 16
14	-		* WASHER, Shakeproof, Ext. 5/16
15	-		* WASHER, Shakeproof, Ext. M6
16	77304BNGS		SUPPORT, Engine
17	2830598SM		SCREW
18	195404GS		STEPPER MOTOR
19	93074BRGS		SUPPORT, Heatshield
20	B4986GS		DECAL, Ground
21	194155GS		KIT, Vibration Mount
22	87680GS		NUT
23	-		* CAPSCREW, Hex Head, M6-1 x 40
24	194951GS		HEAT SHEILD ASSEMBLY
25	191190GS		CAP
26	74908GS		TAPTITE, M5 - 0.8 x 10
27	-		* CAPSCREW, Hex Head, M8 - 1.25 x 20
28	-		* WASHER, Lock, 5/16 M8
29	-		* CAPSCREW, Hex Head, M8-1.25 x 25
30	194543GS		KIT, Hardware, Throttle Linkage
31	200310GS		DECAL, Exhaust Warning
32	-		* NUT, 1/4-20
33	-		* WASHER, Lock, 1/4
34	195422GS		COVER, RBC Plastic w/ Cap
35	791745		KIT, Hose, Fuel
36	201348GS		JACK, Coaxial
37	B2153GS		SCREW, Self Driller, 12-14 x 7/8
38	192376GS		SCREW, Thread Forming, 12-24 x 1/2
39	B4300GS		HHS, Trilobular, 1/4 - 20 x 1/2
40	198221GS		KIT, Hardware, Fuel Tank -(Includes Qty. 4)
41	310574GS		VALVE-FUEL
42	192351GS		LUG, 1/4
43	691656		SOLENOID
44	202954GS		FUEL TANK ASSEMBLY -(Includes Ref. No. 41)
45	314951GS		CAP, Tank Fuel

Footnotes:

**Contact engine manufacturer for parts and service.

* Items without part numbers are common fasteners and are available at your local hardware store.

Main Unit (317669)

Note: Unless noted otherwise, use the standard torque specifications

Mfg. No: 030207-01

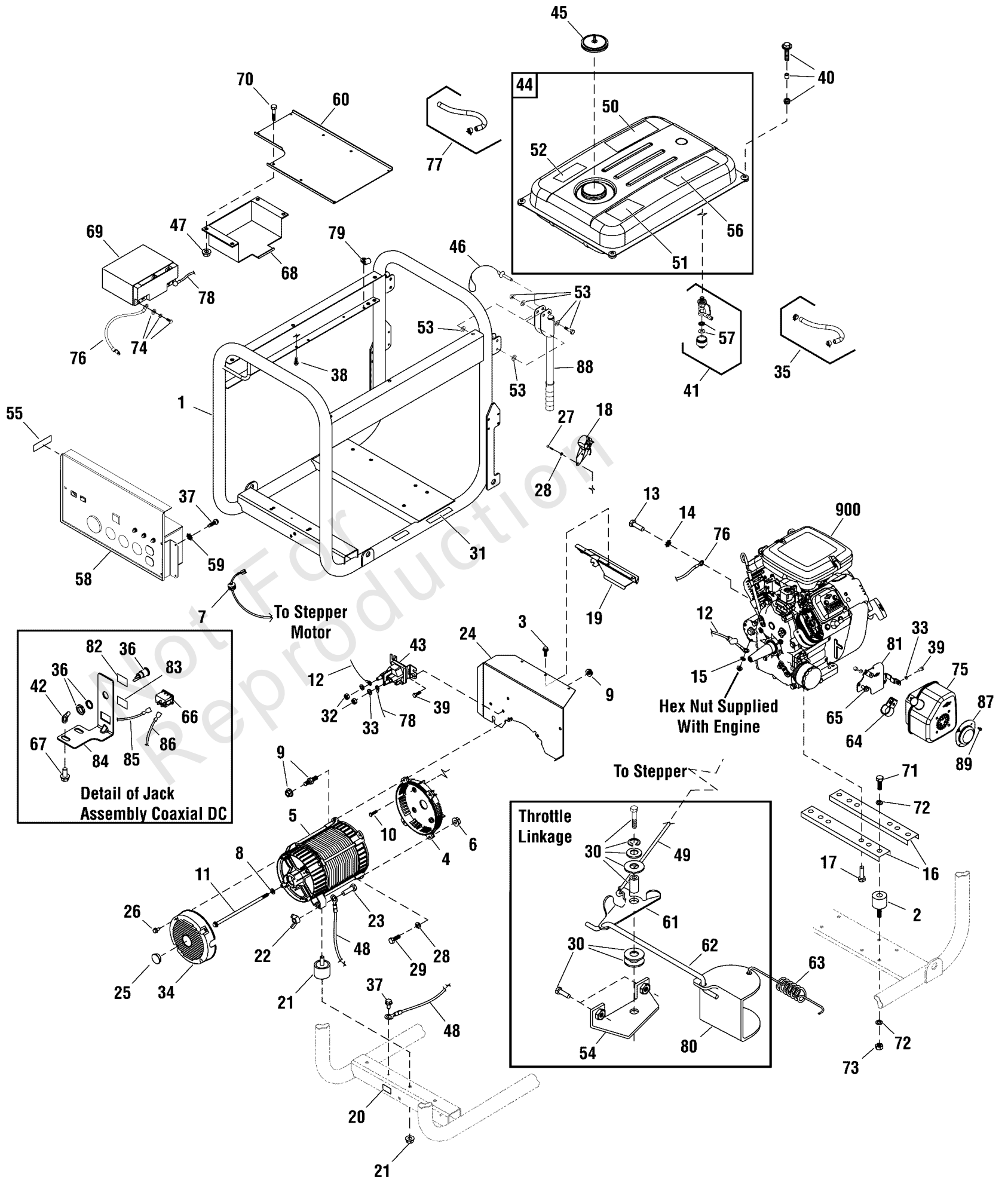

Main Unit (317669)

REF NO	PART NO	QTY	DESCRIPTION
46	B4135GS		PIN, Handle Release
47	77395GS		LOCKNUT, M6
48	14353621GS		WIRE, Ground
49	95920GS		LINKAGE, Stepper Motor
50	188333GS		DECAL, Instruction, Fuel
51	194984GS		DECAL, Warning
52	94480GS		DECAL, Operating Instructions
53	194034GS		KIT, Hardware, Fold Down Handle
54	95349GS		PLATE, Adjust
55	197797GS		DECAL, Fuel Shutoff
56	202997GS		DECAL, Warning, CO
57	189759GS		KIT, Fuel Valve Repair
58	200326GS		CONTROL PANEL
59	-		* WASHER, Ext #10, Shakeproof
60	193512GS		SUPPORT, Tray Battery
61	95348GS		BRACKET, Bell Crank
62	95921GS		LINKAGE, Bell Crank
63	96717GS		SPRING
64	690898		CLAMP
65	-		* CAPSCREW, Hex Head, M8-1.25 x 16
66	87799GS		SWITCH, Rocker
67	90388GS		SCREW, M6-1 x 12, Taptite
68	192985GS		TRAY, Battery
69	316345GS		BATTERY
70	-		* CAPSCREW, Hex Head, M6-1.0 x 12
71	-		* CAPSCREW, Hex Head, 3/8-16 x 3/4
72	-		* WASHER, Lock, 3/8
73	-		* NUT, 3/8-16
74	315546GS		KIT, Hardware, Battery
75	692099		MUFFLER
76	185939TGS		WIRE
77	315017GS		HOSE, Vapor
78	189302RGS		WIRE
79	315831GS		CLAMP
80	200107GS		BRACKET
81	691513		BRACKET
82	198800GS		DECAL
83	197159GS		DECAL
84	200816GS		BRACKET
85	312236GS		WIRE
86	312239GS		WIRE
87	794945		SPARK ARRESTER
88	B193200GS		HANDLE
89	94896GS		SCREW
900	-		** ENGINE
--	BB3061GS		BOTTLE, Oil -(Not Illustrated)
--	BB3061BGS		BOTTLE, Oil -(Not Illustrated)

Footnotes:

**Contact engine manufacturer for parts and service.

* Items without part numbers are common fasteners and are available at your local hardware store.

Main Unit (317669)

Note: Unless noted otherwise, use the standard torque specifications

Mfg. No: 030207-01

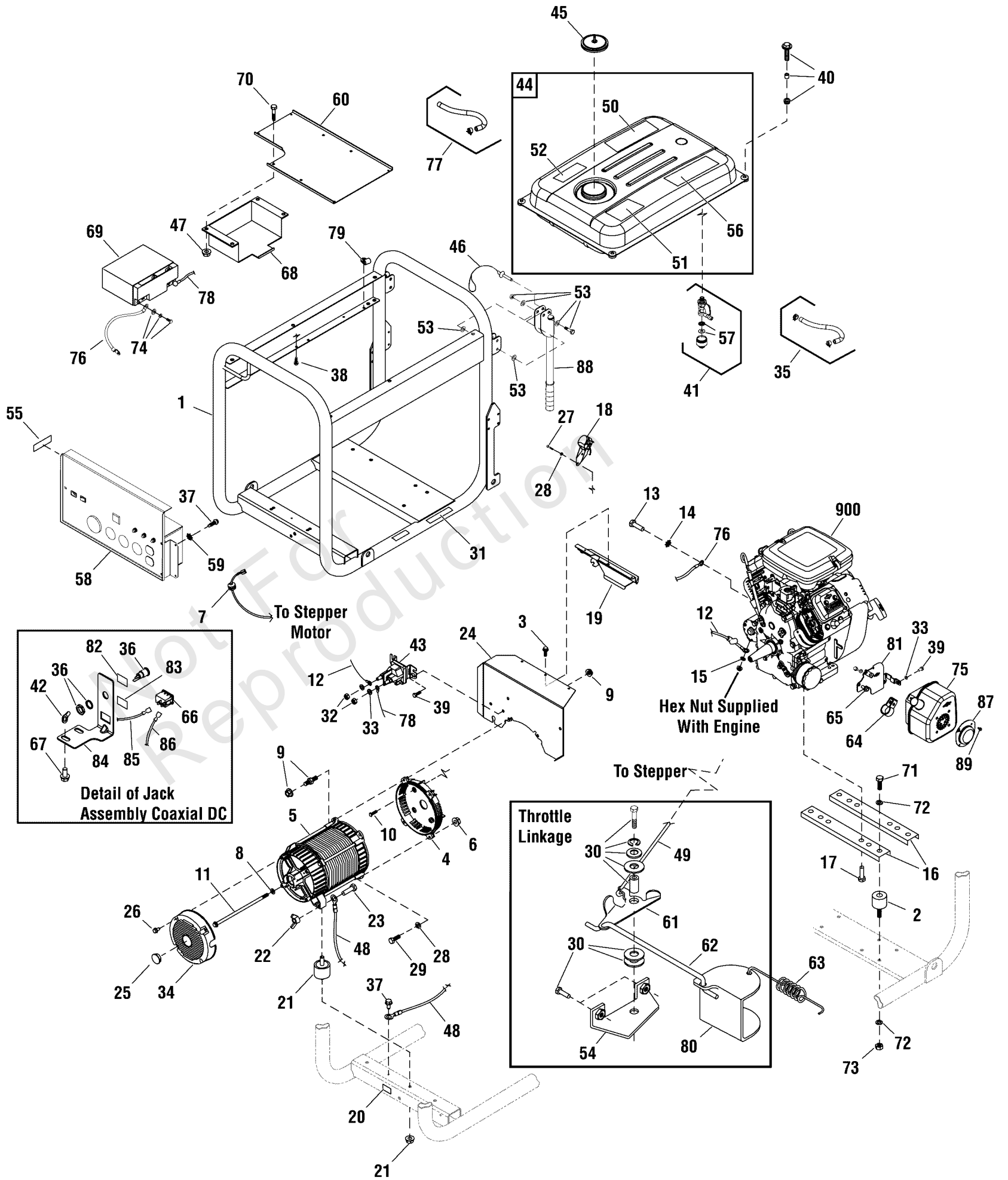

Main Unit (317669)

REF NO	PART NO	QTY	DESCRIPTION
--	B4177GS		CHARGER, Battery -(Not Illustrated)
--	43438GS		PLUG -(Not Illustrated)
--	37806GS		PLUG -(Not Illustrated)
--	B4767GS		COVER, Storage -(Not Illustrated)
--	93568GS		PLUG -(Not Illustrated)
--	65787GS		CABLE, Battery Charger -(Not Illustrated)

Not For
Reproduction

Footnotes:

**Contact engine manufacturer for parts and service.

* Items without part numbers are common fasteners and are available at your local hardware store.

Wheel Kit (200892)

Note: Unless noted otherwise, use the standard torque specifications

Mfg. No: 030207-01

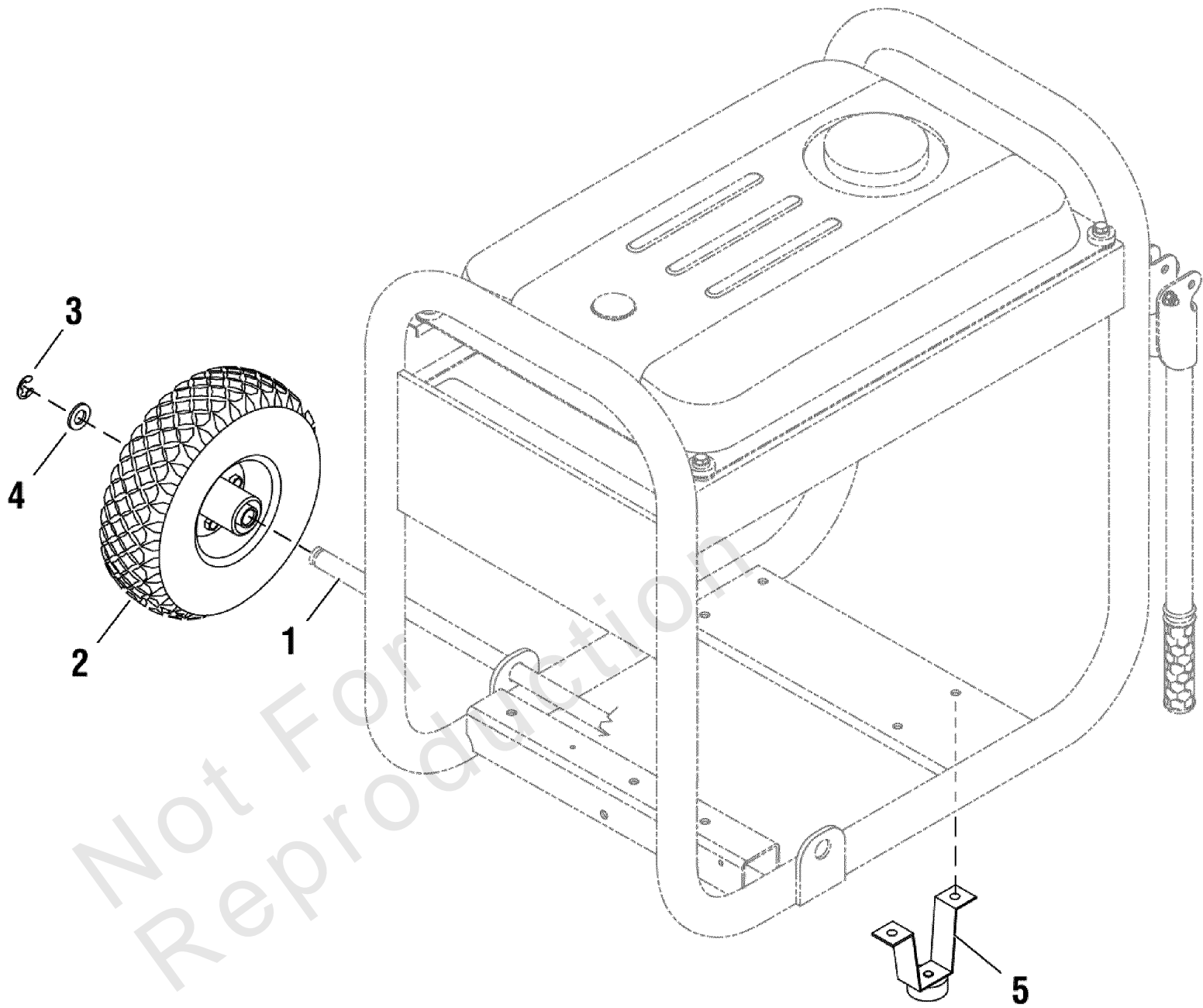

Wheel Kit (200892)

REF NO	PART NO	QTY	DESCRIPTION
1	191267JGS		AXLE
2	209885GS		WHEEL
3	191265GS		E-RING, 5/8
4	-		* WASHER, 5/8
5	203977GS		SUPPORT, Leg
--	200913GS		KIT, Hardware, Wheel -(Not Illustrated)

Not For
Reproduction

Footnotes:

* Items without part numbers are common fasteners and are available at your local hardware store.

Wiring Diagram (199939WD)

Note: Unless noted otherwise, use the standard torque specifications

Mfg. No: 030207-01

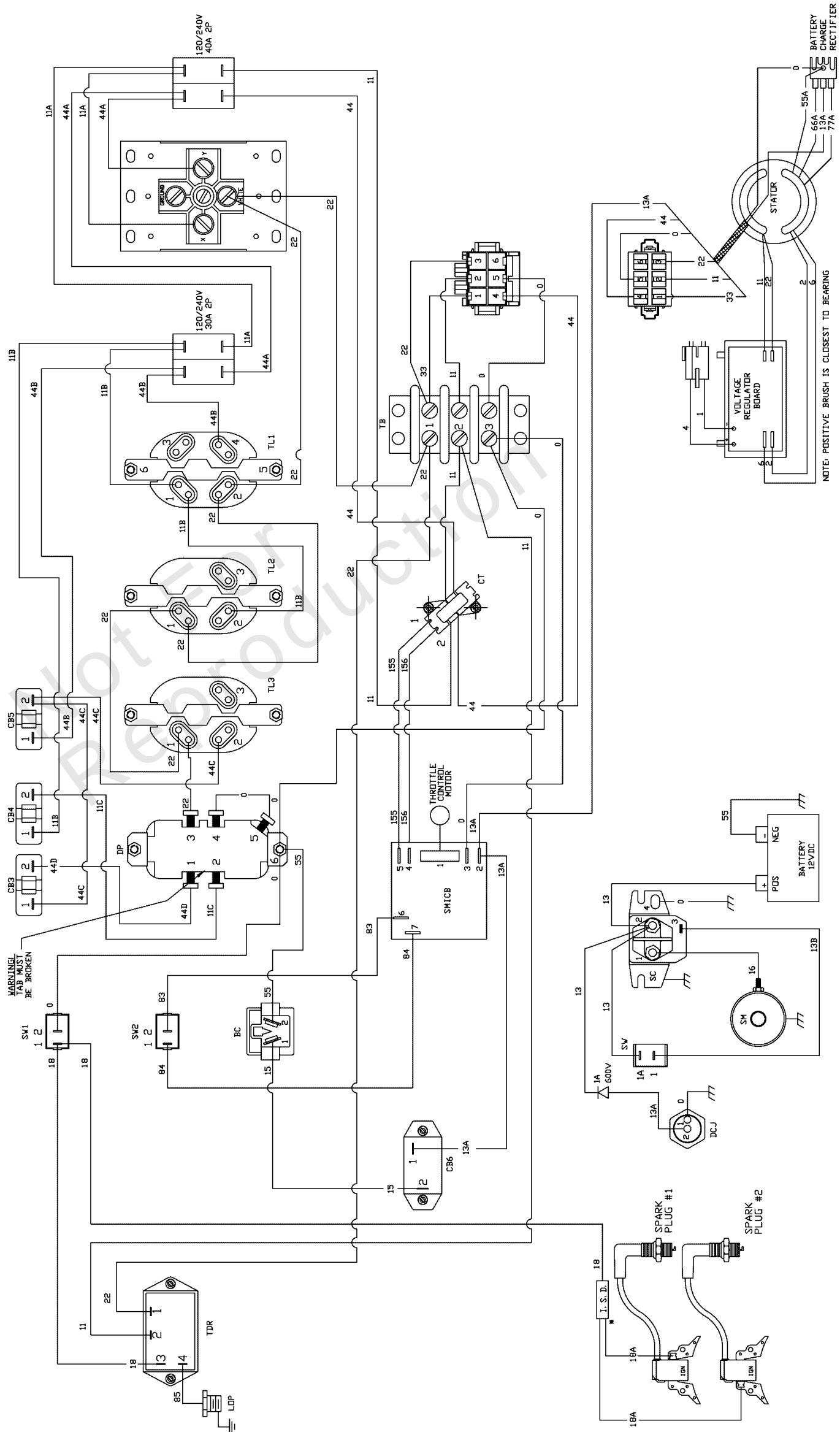

Wiring Diagram (199939WD)

REF NO	PART NO	QTY	DESCRIPTION
--	-		Wiring Diagram Only
--	WARNING		Warning Generator Voltage Could Cause Electrical Shock or Burn Resulting in Death Or Serious Injury. To Avoid Electrical Shock Or Burn Hazard, Please Refer Service To Qualified Personnel.

Not For
Reproduction

Wiring Schematic (199939WS)

Note: Unless noted otherwise, use the standard torque specifications

Mfg. No: 030207-01

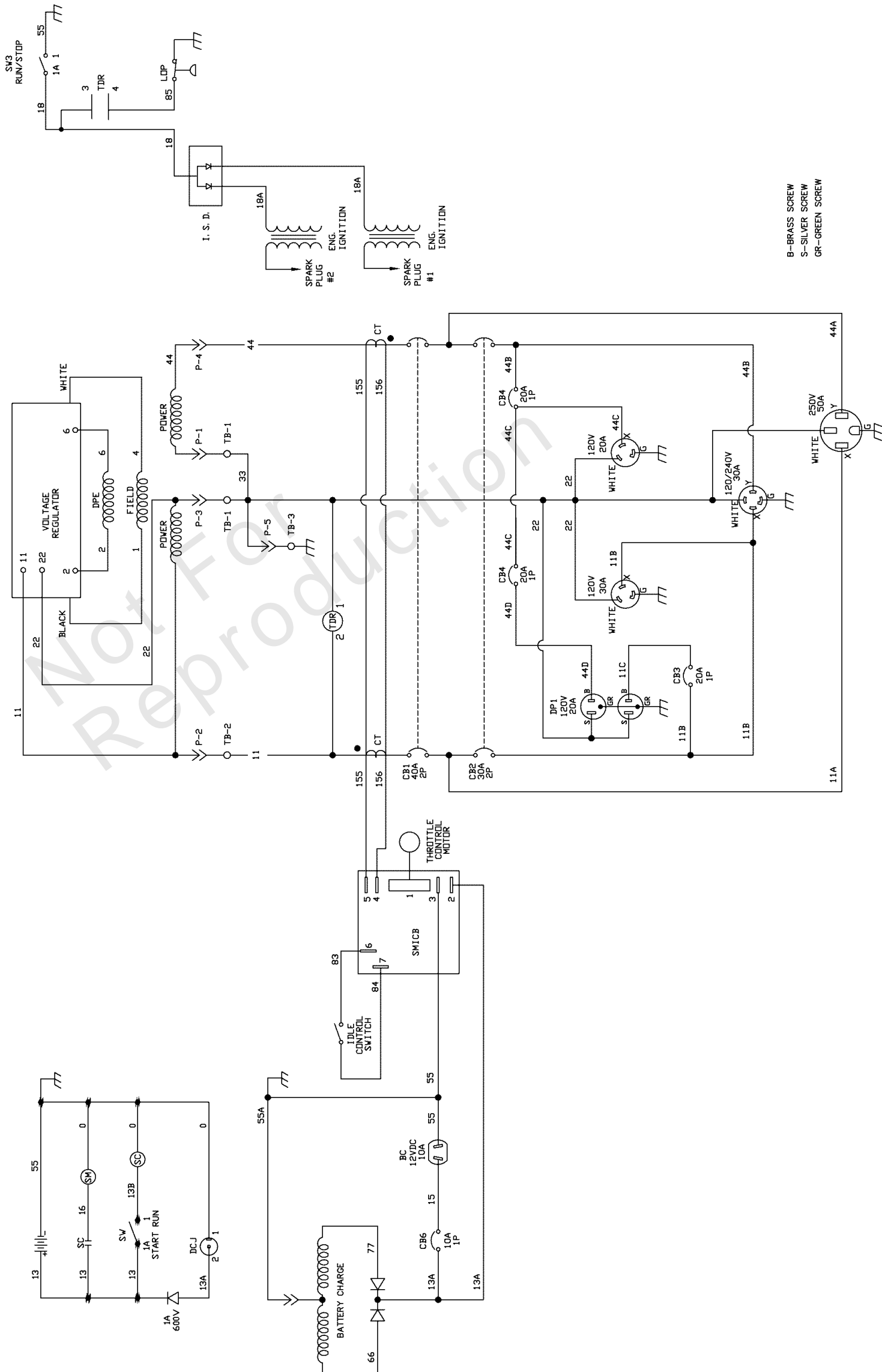

Wiring Schematic (199939WS)

REF NO	PART NO	QTY	DESCRIPTION
--	-		Wiring Schematic Only
--	WARNING		Warning Generator Voltage Could Cause Electrical Shock or Burn Resulting in Death Or Serious Injury. To Avoid Electrical Shock Or Burn Hazard, Please Refer Service To Qualified Personnel.

Not For
Reproduction

Hardware Identification & Torque Specifications

Torque Specification Chart								
FOR STANDARD METRIC MACHINE HARDWARE (Tolerance ± 20%)								
Property Class	5.6		8.8		10.9		12.9	
	Class 5.6		Class 8.8		Class 10.9		Class 12.9	
Size Of Hardware	in/lbs	Nm.	in/lbs	Nm.	in/lbs	Nm.	in/lbs	Nm.
	ft/lbs		ft/lbs		ft/lbs		ft/lbs	
M3	5.88	.56	13.44	1.28	19.2	1.80	22.92	2.15
M4	13.44	1.28	30.72	2.90	43.44	4.10	52.56	4.95
M5	26.4	2.50	60.96	5.75	5.97	8.10	7.15	9.7
M6	44.64	4.3	7.3	9.9	10.3	14	12.1	16.5
M7	5.2	7.1	12.1	16.5	16.9	23	19.9	27
M8	7.7	10.5	17.7	24	25	34	29	40
M10	15	21	35	48	50	67	59	81
M12	26	36	61	83	86.2	117	103	140
M14	42	58	101	132	136	185	162	220
M16	64	88	147	200	210	285	250	340
M18	89	121	202	275	287	390	346	470
M20	126	171	290	390	405	550	486	660
M22	169	230	390	530	559	745	656	890
M24	217	295	497	375	708	960	840	1140
M27	320	435	733	995	1032	1400	1239	1680
M30	435	590	995	1350	1401	1900	1681	2280
M33	590	800	1349	1830	1902	2580	2278	3090
M36	759	1030	1740	2360	2441	3310	2935	3980
M39	988	1340	2249	3050	3163	4290	3798	5150

Torque Specification Chart						
FOR STANDARD MACHINE HARDWARE (Tolerance ± 20%)						
Hardware Grade	No Marks		SAE Grade 5		SAE Grade 8	
	SAE Grade 2		SAE Grade 5		SAE Grade 8	
Size Of Hardware	in/lbs	Nm.	in/lbs	Nm.	in/lbs	Nm.
	ft/lbs		ft/lbs		ft/lbs	
8-32	19	2.1	30	3.4	41	4.6
8-36	20	2.3	31	3.5	43	4.9
10-24	27	3.1	43	4.9	60	6.8
10-32	31	3.5	49	5.5	68	7.7
1/4-20	66	7.6	8	10.9	12	16.3
1/4-28	76	8.6	10	13.6	14	19.0
5/16-18	11	15.0	17	23.1	25	34.0
5/16-24	12	16.3	19	25.8	29	34.0
3/8-16	20	27.2	30	40.8	45	61.2
3/8-24	23	31.3	35	47.6	50	68.0
7/16-14	30	40.8	50	68.0	70	95.2
7/16-20	35	47.6	55	74.8	80	108.8
1/2-13	50	68.0	75	102.0	110	149.6
1/2-20	55	74.8	90	122.4	120	163.2
9/16-12	65	88.4	110	149.6	150	204.0
9/16-18	75	102.0	120	163.2	170	231.2
5/8-11	90	122.4	150	204.0	220	299.2
5/8-18	100	136	180	244.8	240	326.4
3/4-10	160	217.6	260	353.6	386	525.0
3/4-16	180	244.8	300	408.0	420	571.2
7/8-9	140	190.4	400	544.0	600	816.0
7/8-14	155	210.8	440	598.4	660	897.6
1-8	220	299.2	580	788.8	900	1,244.0
1-12	240	326.4	640	870.4	1,000	1,360.0

The guides and ruler furnished below are designed to help you select the appropriate hardware.

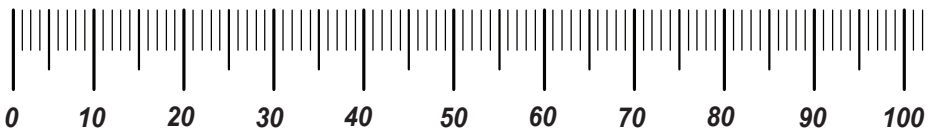

Nut, M8

Thread Diameter (mm)

Inside Diameter (in) Threads per inch

Nut, 1/2-16

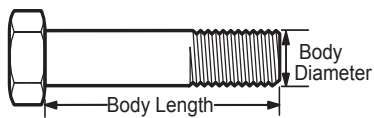

Screw, M8- 1.25 x 25

Thread Diameter (mm) Distance between threads (mm) Body Length (mm)

Body Diameter Threads per inch Body Length (in)

Screw, 1/2- 16 x 2



Standard Hardware Sizing

When a washer or nut is identified as 1/2" (M8), this is the *Nominal size*, meaning the *inside diameter* is 1/2 inch (8mm metric thread diameter); if a second number is present it represents the *threads per inch* (distance between threads).

When bolt or capscrew is identified as 1/2 - 16 x 2" (M8 - 1.25 x 50), this means the *Nominal size*, or body diameter is 1/2 inch (8mm metric thread diameter), the second number, 16, represents the *threads per inch*, (*distance between threads*). The final number is the body length of the bolt or screw, 2 inches (50mm).

NOTES

- These torque values are to be used for all hardware excluding: locknuts, self-tapping screws, thread forming screws, sheet metal screws and socket head setscrews.
- Recommended seating torque values for locknuts:
 - for prevailing torque locknuts - use 65% of grade 5 torques.
 - for flange whizlock nuts and screws - use 135% of grade 5 torques.
- Unless otherwise noted on assembly drawings, all torque values must meet this specification.

Common Hardware Types

Hex Head Capscrew



Washer



Carriage Bolt

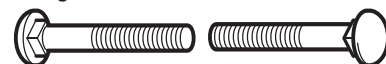

Hex Nut

Wrench & Fastener Size Guide

1/4" Bolt or Nut Wrench—7/16"	5/16" Bolt or Nut Wrench—1/2"	3/8" Bolt or Nut Wrench—9/16"	7/16" Bolt or Nut Wrench (Bolt)—5/8" Wrench (Nut)—11/16"	1/2" Bolt or Nut Wrench—3/4"
M6 Bolt or Nut Wrench—10mm	M8 Bolt or Nut Wrench—13mm	M10 Bolt or Nut Wrench—17mm	M12 Bolt or Nut Wrench—19mm	M14 Bolt or Nut Wrench—22mm

